

ENGINEERED LIFTING SOLUTIONS

HOISTING FOR EXTREME APPLICATIONS



**ARTICULATED LOW HEADROOM
TROLLEY HOIST COMBINATION**

1,000 KG – 10,000 KG LIFTING CAPACITY



**ATEX
Explosion Protected**

Leaflet No. KITO-83885:01

ARTICULATED LOW HEADROOM TROLLEY HOIST COMBINATION

1,000 KG – 10,000 KG LIFTING CAPACITY



ATEX
Explosion Protected

Designed and manufactured according to:

- ▶ EC machinery directive 2006/42/EC
- ▶ ATEX Directive 2014/34/EU
- ▶ EN13157
- ▶ Manufactured in the Netherlands

Standard features:

- ▶ Designed for extremely small curved beams
- ▶ Suitable for extremely narrow spaces in and low headroom applications
- ▶ Equipment classification Gas II 2G EX h IIB T3 Gb (zone 1)
- ▶ Equipment classification Dust II 2D EX h IIB T200°C Db (zone 21)
- ▶ Low pulling force on the hand chain
- ▶ Chain hoist executed with double safety pawl, safe and sure brakes
- ▶ Chain hoist with overload protection by slipping clutch
- ▶ Surface treatment 2 layer paint system and power coating, colour Munsell 6YR6/14
- ▶ Nickel plated load chain, grade V (G 100) in acc. with standard EN818-7
- ▶ Hand chain electric galvanized
- ▶ Trolley wheels with life time lubricated bearings
- ▶ Wheel break support and anti-tilt device integrated
- ▶ Rubber buffers mounted on trolley
- ▶ Ambient temperature -20°C / +40°C

Optional:

- ▶ Available in equipment class Gas II 2G EX h IIC T3 Gb (zone 1)
- ▶ Available in equipment class Dust II 2D EX h IIIC T135°C Db (zone 21)
- ▶ Temperature class T4 / T135°C will be observed separately for each project
- ▶ Suitable for ambient temperature -40°C +40°C
- ▶ Special surface protection acc. to ISO 12944
- ▶ 3.1 load test certificate
- ▶ Canvas chain bag, steel or stainless steel container
- ▶ Solid bronze wheels
- ▶ Parking device for parking in unloaded condition
- ▶ Stainless steel 316 load chain and hand chain
- ▶ Stainless steel nameplate with tag number

Remark:

** The articulated low headroom trolley hoist units are executed with a fixed suspension set within the range of the beam width as mentioned in the tables. The minimum radius is mentioned in the table is for indication and need to be verified once the monorail beam is specified.

Explosion Protected:

Equipment is executed with non-sparking materials for fast mechanical contact parts for hand chain movements and internal fast moving hoist parts, extended with unique and reliable bronze coated load hooks.

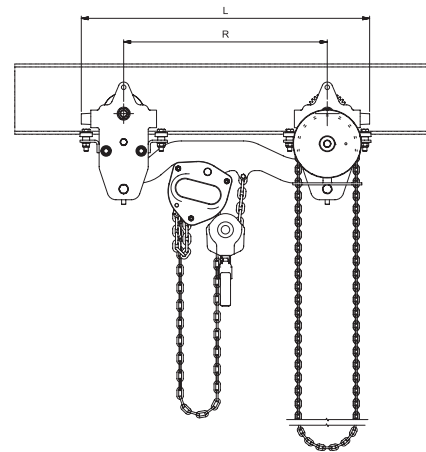
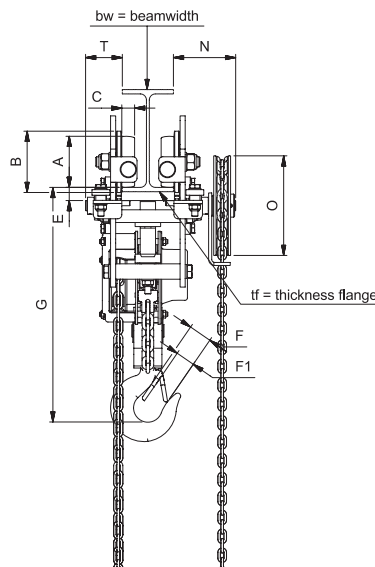

Capacity kg	Article number	Chassis	Fixed beam width in range mm	Min. Beam radius** mm	No. of falls	Chain size mm	max. pulling force hoist kg	max. pulling force trolley kg	Weight 3 meters lift kg	Head- room G	Dimensions										
											A	B	C	E	F	F1	R	T	L	N	O
1,000	83885-01000	11 kN	55-200	500	1	6,3	29	10	40	290	Ø60	Ø75	18	24	34,6	29	400	110	604	65	Ø100
2,000	83885-02000	22 kN	74-250	750	1	8	36	16	59	370	Ø80	Ø100	22	25	40	36	460	122	706	68	Ø100
3,000	83885-03000	33 kN	90-250	750	2	7,1	36	20	85	460	Ø100	Ø120	25	25	46	42,5	580	122	822	72	Ø195
5,000	83885-05000	52 kN	106-305	1000	2	9	34	20	140	558	Ø125	Ø150	30	31	50	46,5	700	138	984	72	Ø270
7,500	83885-07500	104 kN	115-305	1250	3	9	35	19	275	750	Ø160	Ø190	35	35	79,5	72,5	800	150	1280	250	Ø300
10,000	83885-10000	104 kN	115-305	1250	4	9	36	19	300	775	Ø160	Ø190	35	35	79,5	72,5	800	150	1280	250	Ø300

* larger capacities up to 30,000kg on request
** See remark in PDS**

Changes in design and measurements reserved