



Hoist-Trolley units | Hand operated / Overhead crane / EX.

Features:

- Van Leusden overhead cranes are available as complete cranes and as crane kits for self-construction
- Explosion protected model in **Basic/Medium** execution suitable up till Ex Class Ex II 2 G IIB T3 (Zone 1&2) Non Sparking protection of fast moving mechanical contact parts and rubber buffers on crane
- Explosion protected model in **High** execution suitable up till Ex Class Ex II 2 G IIC T3 (Zone 1)
- Non sparking protection of fast moving mechanical contact parts rubber buffers, increased with non sparking protection of crane wheels and hand chains
- The overhead cranes are executed with solid material double flange wheels, suitable for flat rails 50/30 mm

- The cranes are of low maintenance type and have limited wear and tear parts
- The cranes delivered complete with:
 - Manual geared drive
 - Control height 3 m, control chain
 - Surface protection Shot blasting + primer + top coat in RAL1007
 - S.W.L. Sticker
 - Users manual
 - Crane kits for crane-constructors:
 - A complete set of wheel boxes, with transversal shaft, bearing blocks, hand chain wheel, hand chain, accompanied by a dimensional sketch. Shot blasted + primer

- Basic welding execution, Crane girder to be welded to the wheelboxes
- Crane girder to be provided by crane-constructor.

Optional:

- Wheel boxes with screw fittings to the crane girder.
- Higher capacities, double girder cranes, low headroom types
- Special executions as low headroom etc.
- Special surface treatment
- For suitable Hoist and Trolley units see our other catalogue pages

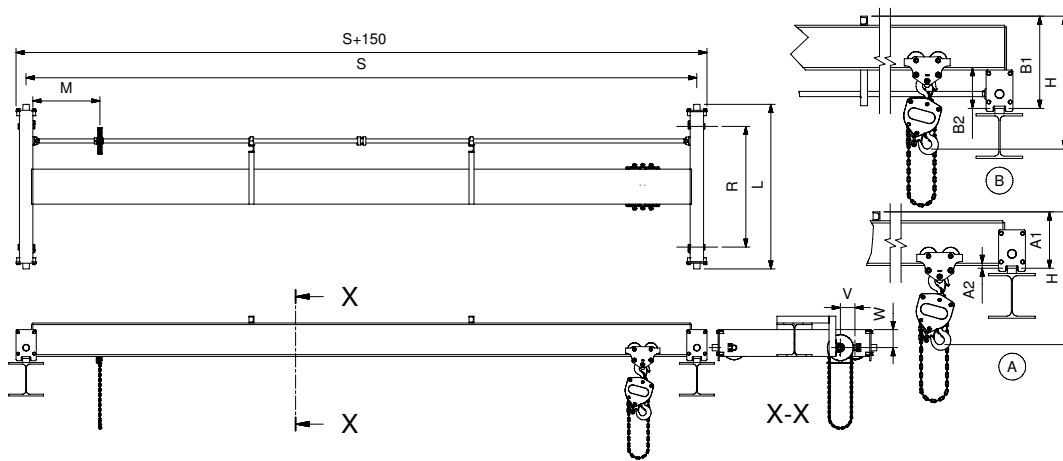

Technical information:

- 1) Max. Girder deflection 1/600 of span. Mentioned values are for complete manual driven cranes.
- 2) Values mentioned between (...) are corresponding a girder deflection of 1/750 of span. This value shall be used for cranes with electric driven hoist and trolley or crane travel motions.
- 3) Changes in dimensions or prices possible without pre-notice.
- 4) Specify A or B type crane with order.

Cranes / Hand operated / Underslung crane / Explosion protected (Art. group 86000) ATEX BASIC/MEDIUM/HIGH																		
S.W.L.	S	R	L	Wheels	A1	A2	B1	B2	Max. Weight. Hoist+Trolley	Max. Wheelbox load	Handchain Force	Crane 86110.. Art. Nr.	Price Crane Excl. Hoist/Trolley BASIC/ MEDIUM Ex II 2G IIB T3 Price €	Price Crane Excl. Hoist/Trolley HIGH Ex II 2G IIC T3 Price €	Crane Kit 86160.. Art.Nr.	Crane Kit BASIC/ MEDIUM Ex II 2G IIB T3 Price €	Crane Kit HIGH Ex II 2G IIC T3 Price €	Screw Fittings Boltset incl. Price €
Kg.	m1) 2)	mm	mm	mm	mm	mm	mm	mm	Kg.	[kN]	Kg.							
500	- 4.10 (- 3.70)	800	1090	125/150	196	21	346	171	100	3.4	10	..05001			..05001			
	- 5.25 (- 4.75)	800	1090	125/150	196	21	346	171		3.8	10	..05002			..05002			
	- 6.75 (- 6.00)	800	1090	125/150	215	22	365	172		3.9	10	..05003			..05003			
	- 8.25 (- 7.40)	1000	1290	125/150	234	22	384	172		4.0	11	..05004			..05004			
1.000	- 3.95 (- 3.55)	800	1090	125/150	215	22	365	172	105	6.0	15	..10001			..10001			
	- 5.00 (- 4.50)	800	1090	125/150	215	22	365	172		6.1	15	..10002			..10002			
	- 6.00 (- 5.50)	800	1090	125/150	234	22	384	172		6.3	15	..10003			..10003			
	- 7.50 (- 6.70)	1000	1290	125/150	253	23	403	173		6.5	17	..10004			..10004			
	- 9.10 (- 8.10)	1200	1490	125/150	273	24	423	174		6.9	20	..10005			..10005			
	- 3.40 (- 3.10)	800	1090	125/150	203	25	353	175		11.1	19	..20001			..20001			
2.000	- 5.75 (- 5.75)	800	1090	125/150	273	24	423	174	150	11.5	21	..20002			..20002			
	- 7.75 (- 7.00)	1000	1290	125/150	293	25	443	175		12.0	23	..20003			..20003			
	- 9.10 (- 8.10)	1200	1490	125/150	313	25	463	178		12.6	24	..20004			..20004			
	- 5.50 (- 4.90)	800	1090	125/150	263	28	413	178		16.8	21	..32001			..32001			
3.200	- 6.50 (- 5.90)	1000	1290	125/150	283	29	433	179	175	17.2	23	..32002			..32002			
	- 9.50 (- 8.80)	1400	1690	125/105	353	27	503	177		18.2	25	..32003			..32003			
	- 11.00 (- 9.90)	1400	1690	125/105	373	28	523	178		18.8	27	..32004			..32004			
5.000	- 5.00 (- 5.00)	800	1130	160/180	305	32	505	232	225	27.1	26	..50001			..50001			
	- 6.25 (- 6.25)	800	1130	160/180	325	33	525	233		27.5	27	..50002			..50002			
	- 9.20 (- 9.20)	1200	1530	160/180	415	33	615	233		29.9	30	..50003			..50003			